



KNIFE-GATE VALVES

L SERIES

GEAR BOX

- It is recommendable for DN greater than 600.
- **A = Max. width** of the valve (without actuator).
B = Max. height of the valve (without actuator).
C = maximum length when the gate is centred.
- Options:
 - Chainwheel
 - Locking devices
 - Non-rising stem
 - Extensions: stand, pipe, plates...
- Actuator including:
 - Cone-shaped gear box
 - Stem
 - Yoke
 - Handwheel
- Standard ratio = 4 to 1 .
- Available: ND50 to ND2000, other ND on request.
- The weights are approximate and vary according to the material and the valve's accessories.

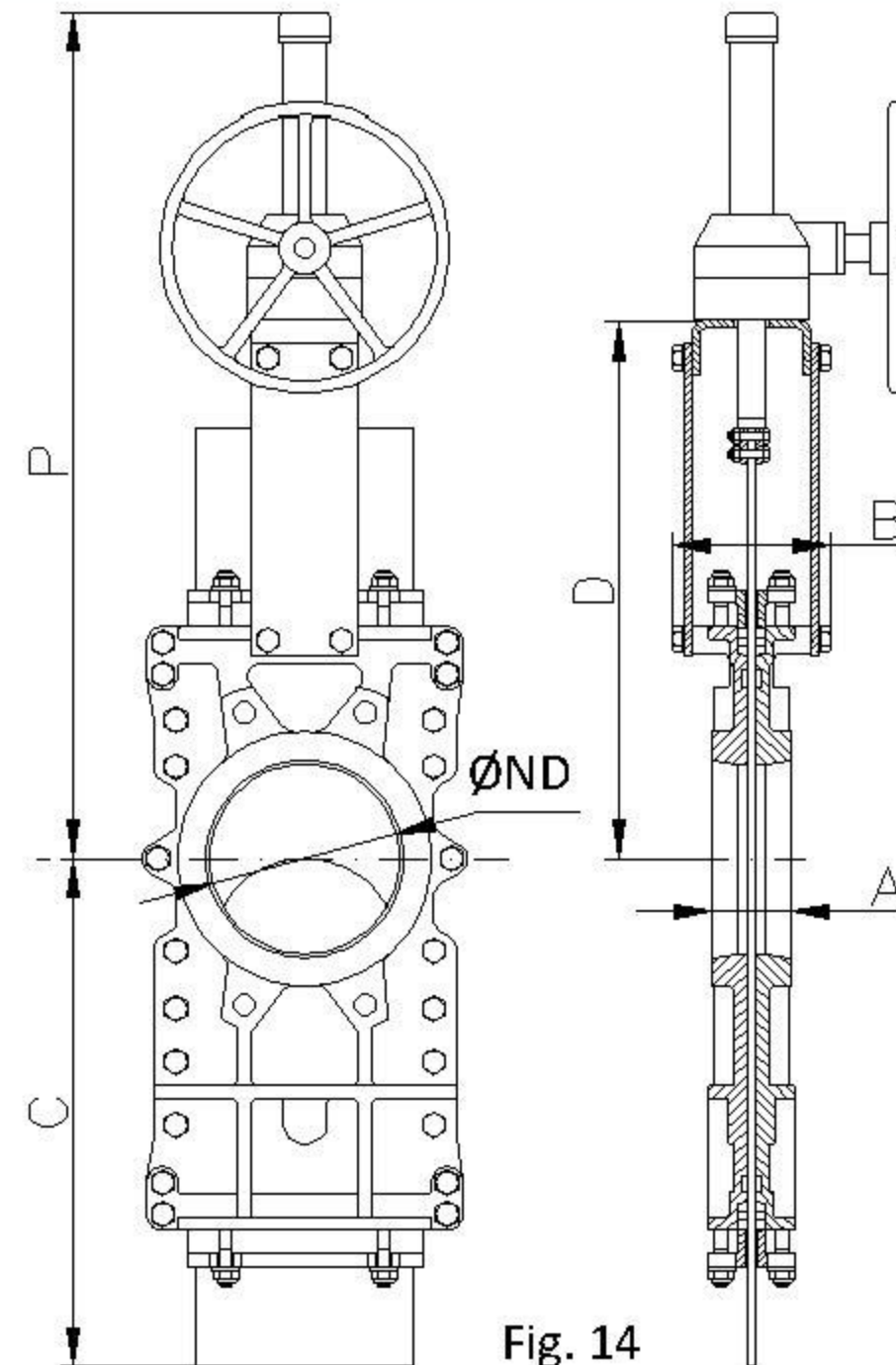

ND	ΔP (Kg/cm ²)	DRAW (Nw)	TORQUE (Nm)	A	B	C	D	P	Weight (kg.)
50	10	894	2.1	40	91	225	243	540	22
65	10	1508	3.5	40	91	265	269	566	23
80	10	2281	5.2	50	91	310	293	591	27
100	10	3561	8.2	50	91	370	334	631	28
125	10	5565	13	50	101	430	367	665	37
150	10	6419	15	60	101	495	419	717	47
200	8	10020	29	60	118	630	525	943	76
250	6	11230	32.5	70	118	770	620	1037	111
300	6	16210	47	70	118	895	726	1171	133
350	5	17740	70	96	290	1050	780	1318	163
400	5	23260	92	100	290	1185	855	1393	247
450	3	22260	89	106	290	1320	975	1662	386
500	3	27470	110	110	290	1455	1064	1752	495
600	3	39850	160	110	290	1720	1244	1981	552
700	2	36880	212	110	320	1995	1425	2320	956
800	2	48980	285	110	320	2230	1615	2610	N.G.
900	2	61230	353	110	320	2465	1823	2913	N.G.
1000	2	77690	457	110	320	2620	1992	3206	N.G.
1100	2	95506	674	150	340	3030	2217	3777	N.G.
1200	2	113710	802	150	340	3250	2351	4042	N.G.
1300	2	133563	943	150	390	3430	2882	4382	N.G.
1400	2	157280	1298	150	390	3680	3250	4852	N.G.
1500	2	180712	1493	170	426	3930	3517	5217	N.G.
1600	2	205780	1904	170	426	4272	3775	5575	N.G.
1700	2	236498	2214	190	440	4615	4008	5908	N.G.
1800	2	264860	2477	190	440	4886	4242	6242	N.G.
1900	2	299502	3213	210	480	5158	4390	6490	N.G.
2000	2	331260	3549	210	480	5430	4540	6740	N.G.

N.G.: Weight not given

table 7